



(19) **United States**  
(12) **Patent Application Publication**  
**Tsai et al.**

(10) **Pub. No.: US 2016/0063921 A1**  
(43) **Pub. Date: Mar. 3, 2016**

(54) **ORGANIC LIGHT-EMITTING DIODE DISPLAY WITH REDUCED CAPACITIVE SENSITIVITY**

(52) **U.S. CL.**  
CPC ..... **G09G 3/3258** (2013.01); **G09G 2320/0252** (2013.01); **G09G 2310/061** (2013.01)

(71) Applicant: **Apple Inc.**, Cupertino, CA (US)  
(72) Inventors: **Tsung-Ting Tsai**, Taipei City (TW); **Vasudha Gupta**, Cupertino, CA (US); **Chin-Wei Lin**, Cupertino, CA (US); **Shih-Chang Chang**, Cupertino, CA (US); **Young Bae Park**, San Jose, CA (US)

(57) **ABSTRACT**  
A display may have an array of organic light-emitting diode display pixels. Each display pixel may have a light-emitting diode that emits light under control of a drive transistor. Each display pixel may also have control transistors for compensation and programming operations. Each display pixel may have six thin-film transistors and one capacitor. One of the six transistors may serve as the drive transistor and may be compensated using the remaining five transistors and the capacitor. The capacitor may have a first terminal coupled to the gate of the drive transistor and a second terminal coupled to the light-emitting diode. In one embodiment, two scan control signals and two emission control signals may be used for each row of display pixels. In another embodiment, a single scan control signal and a single emission control signal may be formed for each row of display pixels.

(21) Appl. No.: **14/469,513**  
(22) Filed: **Aug. 26, 2014**

**Publication Classification**

(51) **Int. Cl.**  
**G09G 3/32** (2006.01)

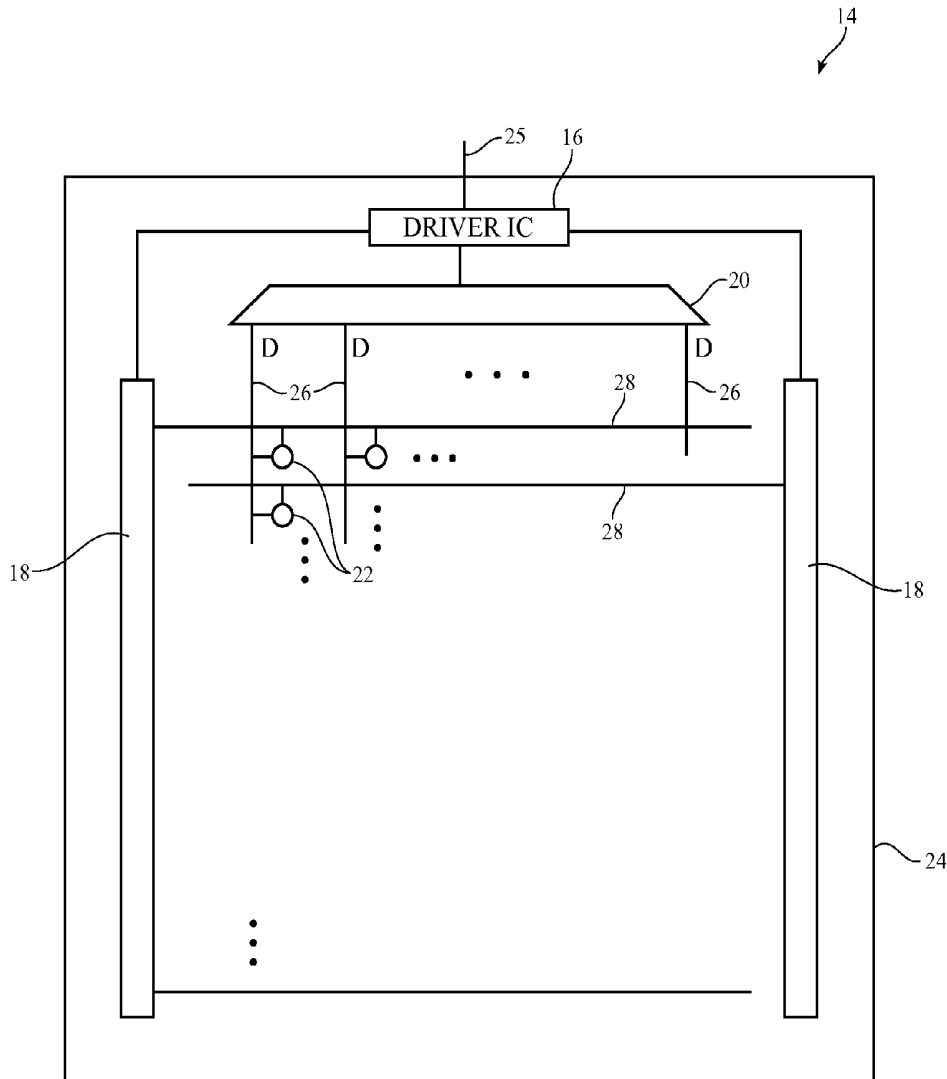

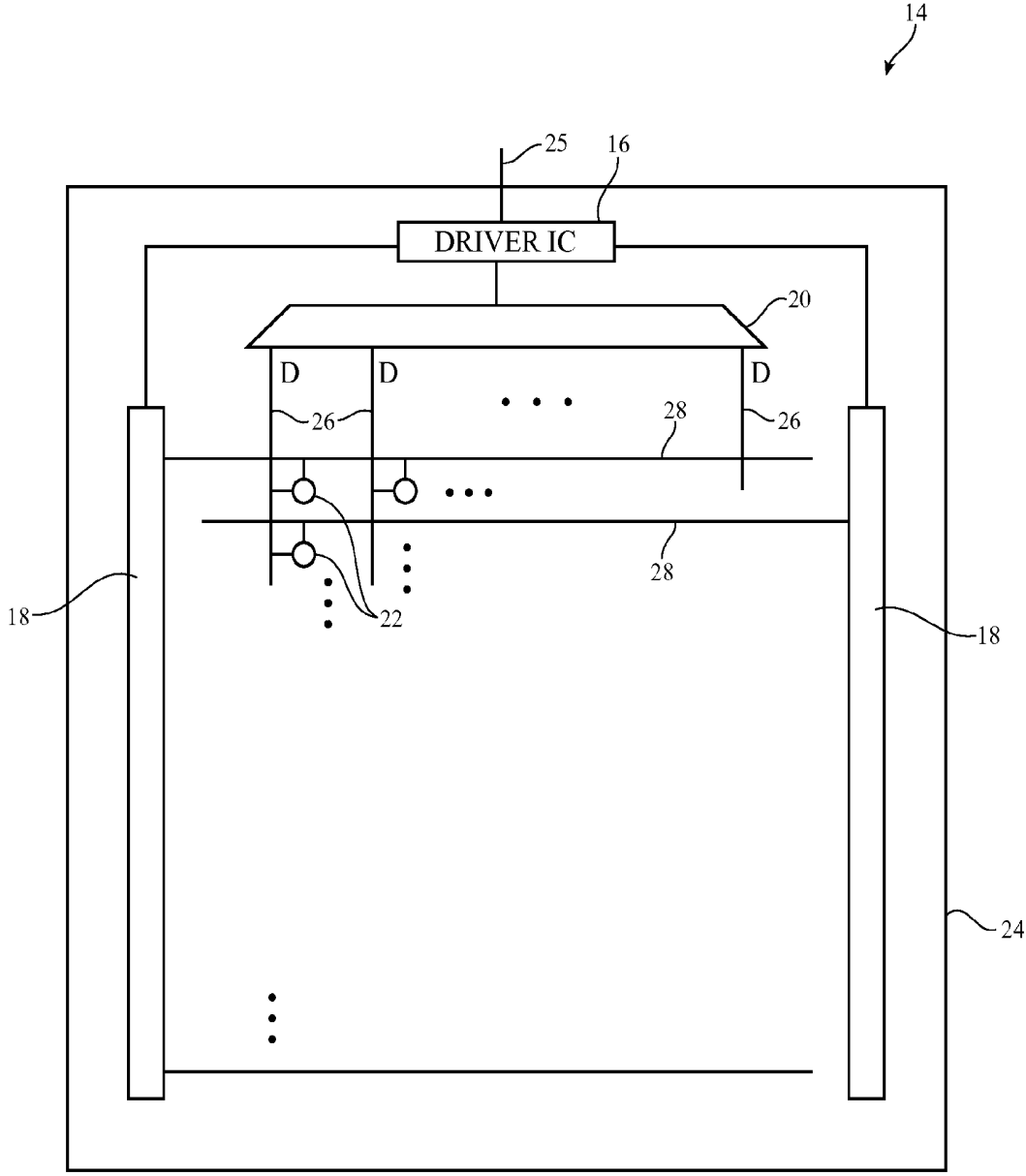

FIG. 1

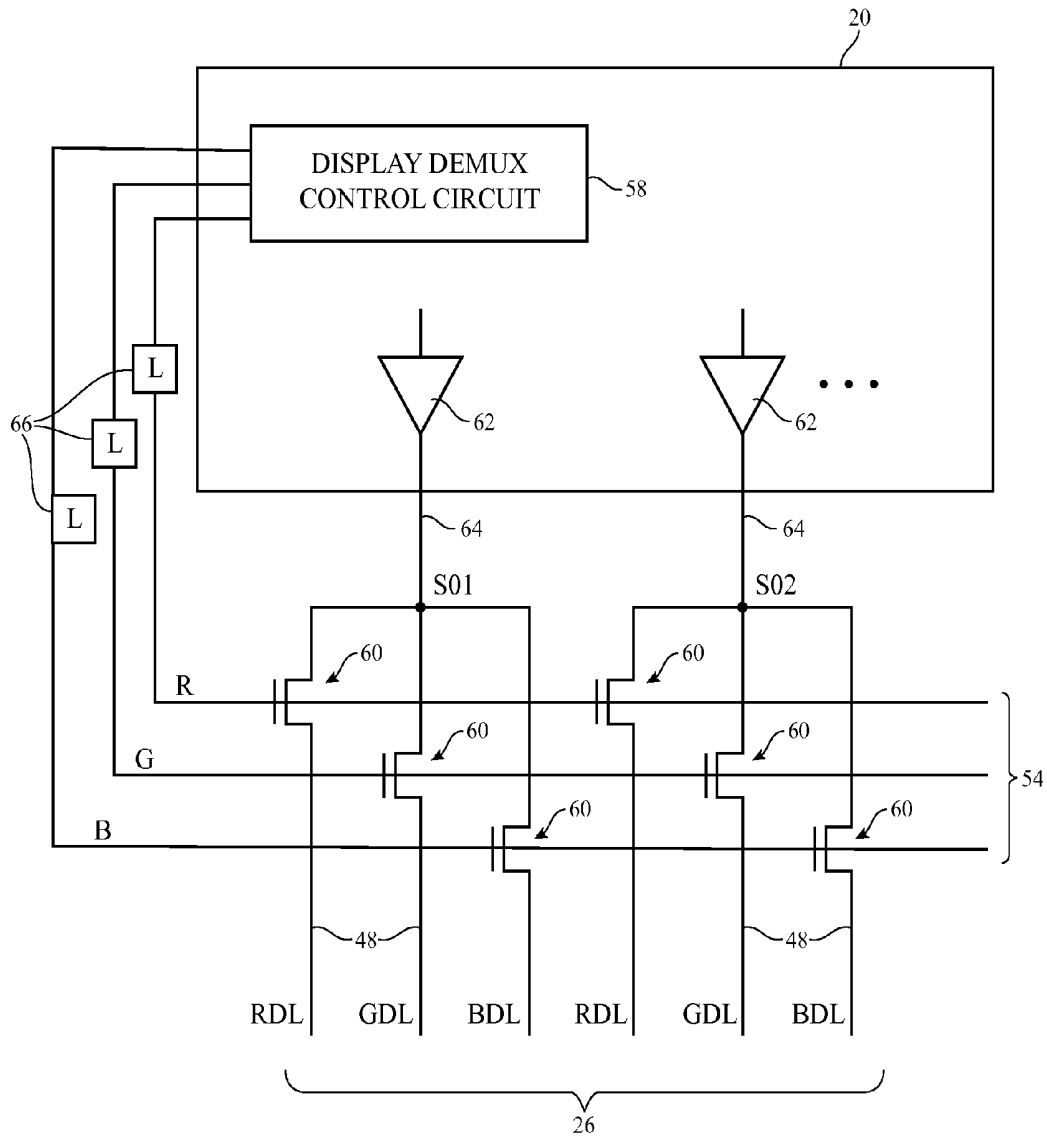

FIG. 2

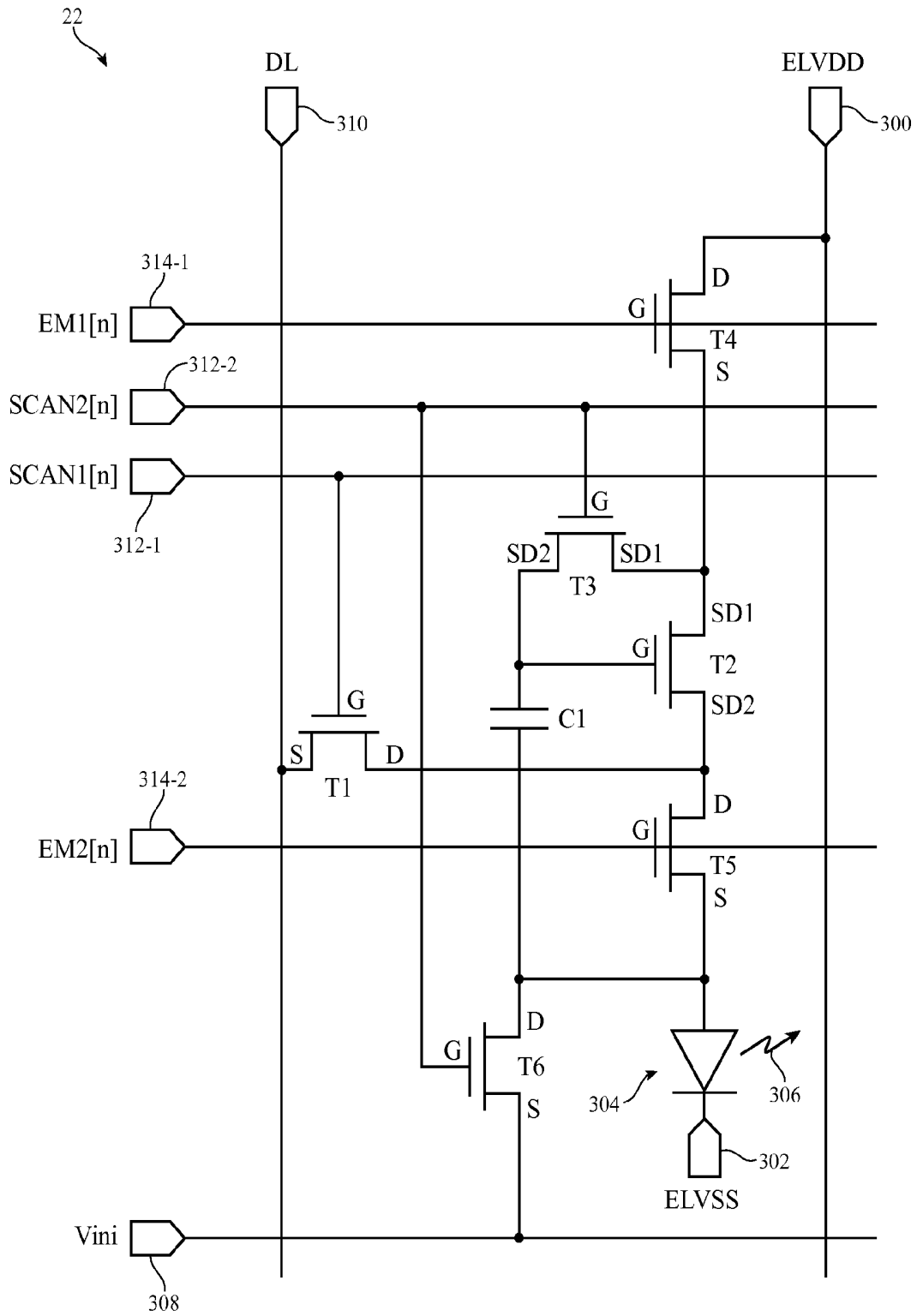

FIG. 3

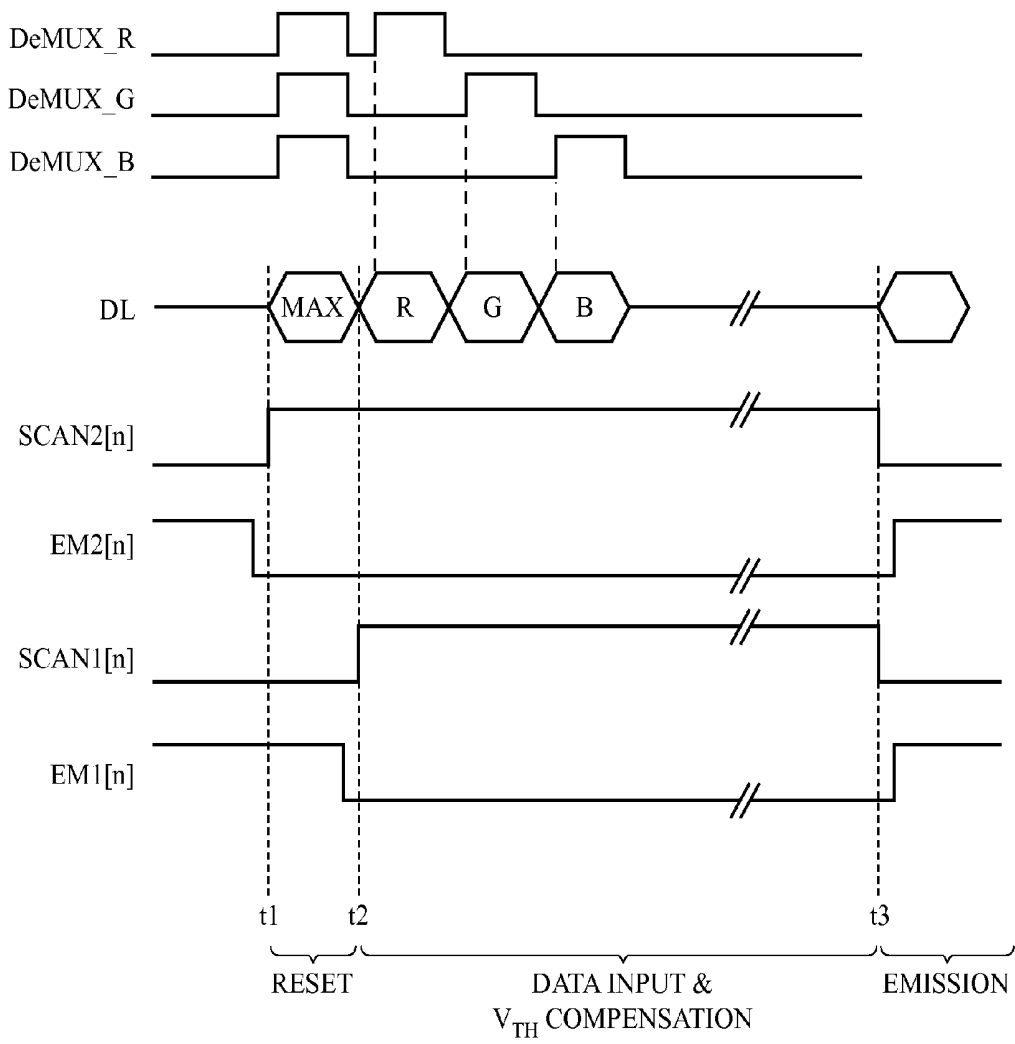

FIG. 4

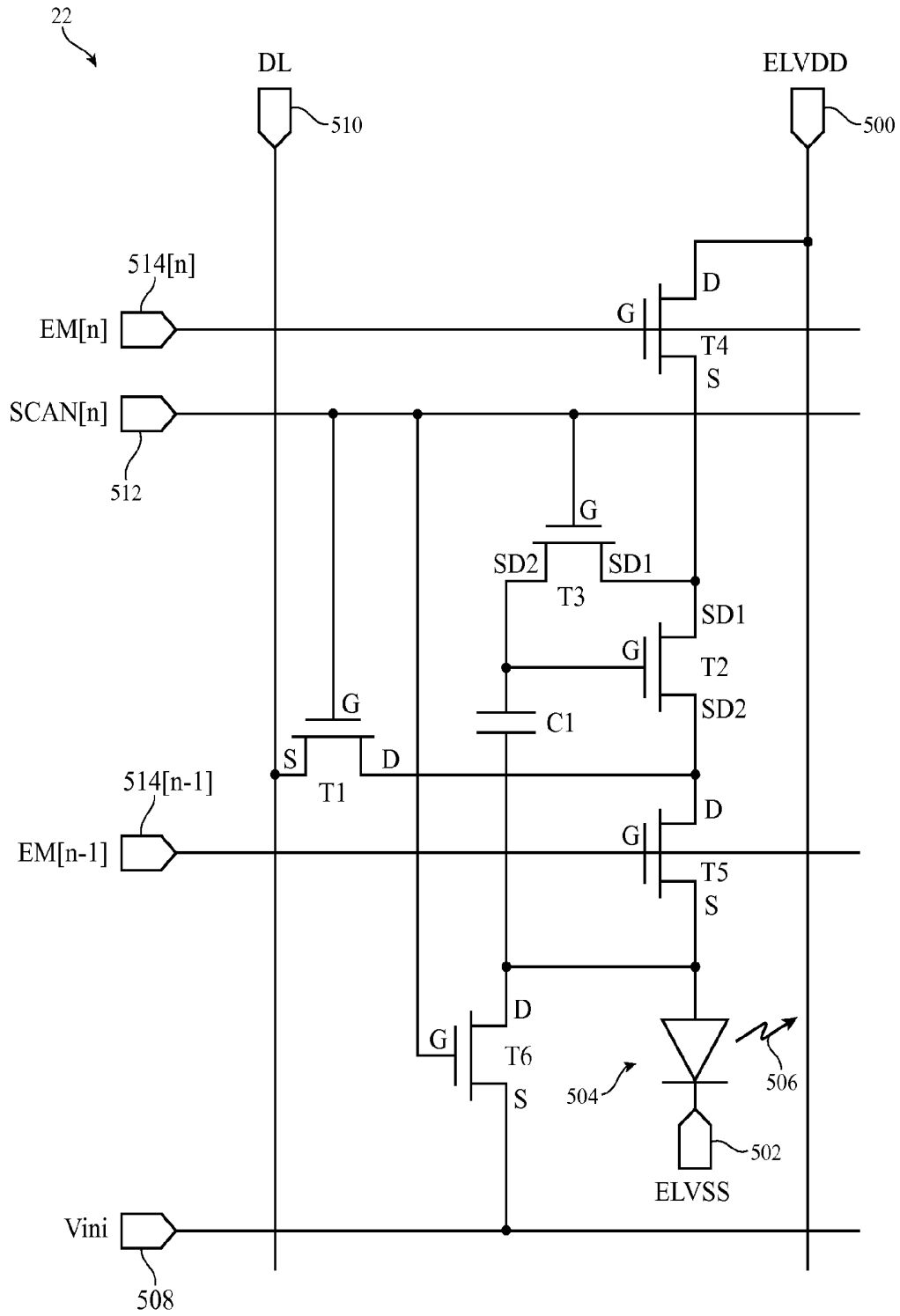

FIG. 5

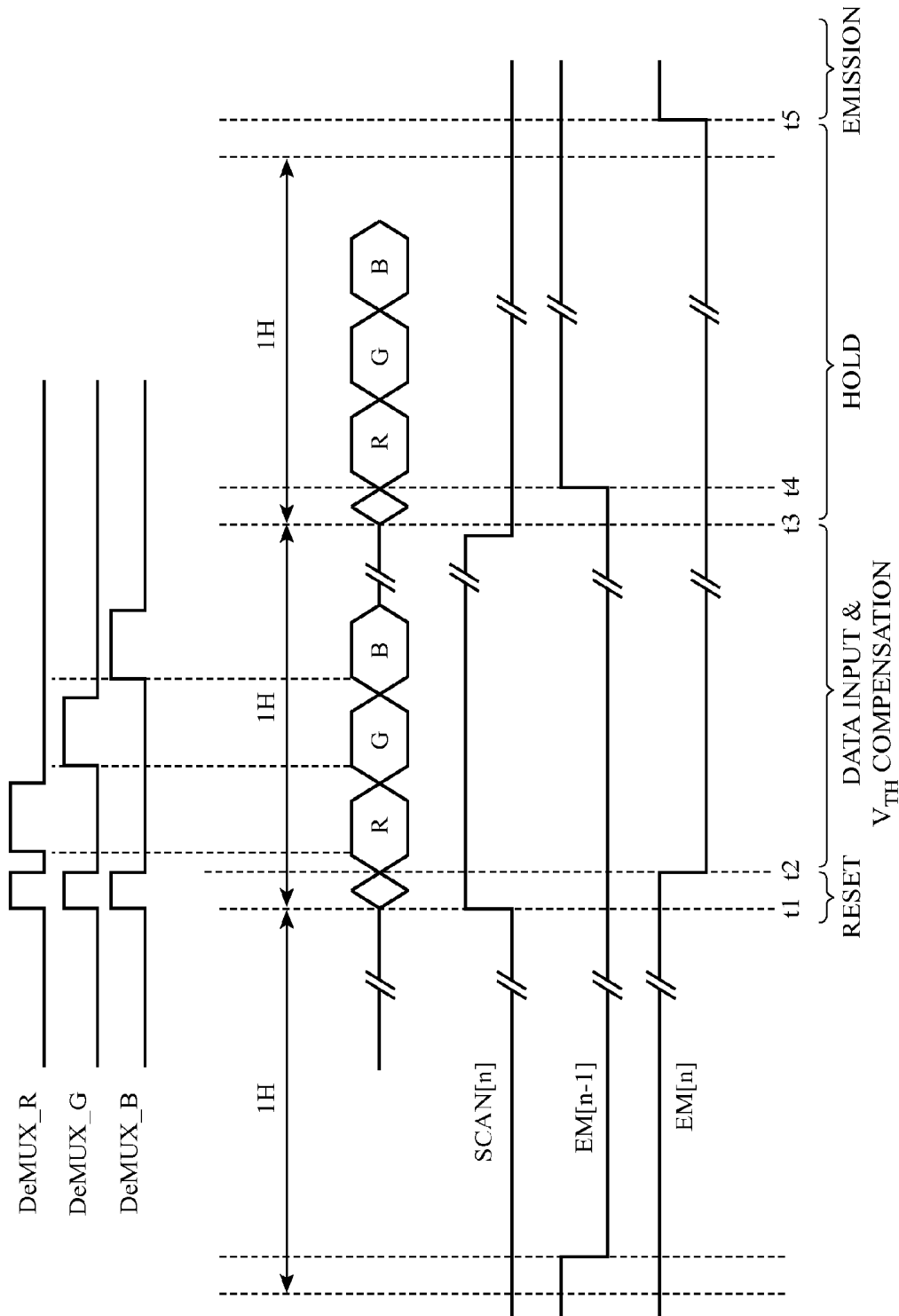

FIG. 6

## ORGANIC LIGHT-EMITTING DIODE DISPLAY WITH REDUCED CAPACITIVE SENSITIVITY

### BACKGROUND

[0001] This relates generally to electronic devices with displays and, more particularly, to display driver circuitry for displays such as organic-light-emitting diode displays.

[0002] Electronic devices often include displays. For example, cellular telephones and portable computers include displays for presenting information to users.

[0003] Displays such as organic light-emitting diode displays have an array of display pixels based on light-emitting diodes. In this type of display, each display pixel includes a light-emitting diode and thin-film transistors for controlling application of a signal to the light-emitting diode to produce light.

[0004] Threshold voltage variations in the thin-film transistors can cause undesired visible display artifacts. For example, threshold voltage hysteresis can cause white pixels to be displayed differently depending on context. The white pixels in a frame may, as an example, be displayed accurately if they were preceded by a frame of white pixels, but may be displayed inaccurately (i.e., they may have a gray appearance) if they were preceded by a frame of black pixels. This type of history-dependent behavior of the light output of the display pixels in a display causes the display to exhibit a low response time. To address the issues associated with threshold voltage variations, displays such as organic light-emitting diode displays are provided with threshold voltage compensation circuitry. Such circuitry may not, however, adequately address all threshold voltage variations, may not satisfactorily improve response times, and may have a design that is difficult to implement.

[0005] It would therefore be desirable to be able to provide a display with improved threshold voltage compensation circuitry.

### SUMMARY

[0006] An electronic device may include a display having an array of display pixels. The display pixels may be organic light-emitting diode display pixels. Each display pixel may have an organic light-emitting diode that emits light and a drive transistor that controls the application of current to the organic light-emitting diode. The drive transistor has an associated threshold voltage.

[0007] Each display pixel may have control transistors for threshold voltage compensation and diode capacitance compensation operations. During compensation operations, the control transistors are controlled so as to compensate the drive transistor for variations in the threshold voltage of the drive transistor and to compensate for variations in the parasitic capacitance associated with the organic light-emitting diode. This ensures that the output of the light-emitting diode will be responsive to the size of the data signal loaded into the display pixel and independent of threshold voltage and its capacitance.

[0008] With one arrangement, each display pixel has six n-type transistor and a single capacitor. One of the six n-type transistors serves as the drive transistor for the display pixel and may be compensated using the remaining five of the n-type transistors and the capacitor. In this arrangement, each row of display pixels may be controlled using two scan con-

trol lines and two emission control lines. With another arrangement, each row of row of display pixel may be controlled using only one scan control line, one emission control line associated with that row, and another emission control line routed from an immediately preceding row.

### BRIEF DESCRIPTION OF THE DRAWINGS

[0009] FIG. 1 is a diagram of an illustrative display such as an organic light-emitting diode display having an array of organic light-emitting diode display pixels in accordance with an embodiment.

[0010] FIG. 2 is a circuit diagram of an image pixel array and associated driver circuitry in accordance with an embodiment of the present invention.

[0011] FIG. 3 is a diagram of an illustrative organic light-emitting diode display pixel of the type that may be used in a display in accordance with an embodiment.

[0012] FIG. 4 is a timing diagram showing signals involved in operating the display pixel circuitry of FIG. 3 in accordance with an embodiment.

[0013] FIG. 5 is a diagram of an illustrative organic light-emitting diode display pixel of the type shown in FIG. 3 with a reduced number of control lines in accordance with an embodiment.

[0014] FIG. 6 is a timing diagram showing signals involved in operating the display pixel circuitry of FIG. 5 in accordance with an embodiment.

### DETAILED DESCRIPTION

[0015] A display in an electronic device may be provided with driver circuitry for displaying images on an array of display pixels. An illustrative display is shown in FIG. 1. As shown in FIG. 1, display 14 may have one or more layers such as substrate 24. Layers such as substrate 24 may be formed from planar rectangular layers of material such as planar glass layers. Display 14 may have an array of display pixels 22 for displaying images for a user. The array of display pixels 22 may be formed from rows and columns of display pixel structures on substrate 24. These structures may include thin-film transistors such as polysilicon thin-film transistors, semi-conducting oxide thin-film transistors, etc. There may be any suitable number of rows and columns in the array of display pixels 22 (e.g., ten or more, one hundred or more, or one thousand or more).

[0016] Display driver circuitry such as display driver integrated circuit 16 may be coupled to conductive paths such as metal traces on substrate 24 using solder or conductive adhesive. Display driver integrated circuit 16 (sometimes referred to as a timing controller chip) may contain communications circuitry for communicating with system control circuitry over path 25. Path 25 may be formed from traces on a flexible printed circuit or other cable. The system control circuitry may be located on a main logic board in an electronic device such as a cellular telephone, computer, television, set-top box, media player, portable electronic device, or other electronic equipment in which display 14 is being used. During operation, the system control circuitry may supply display driver integrated circuit 16 with information on images to be displayed on display 14 via path 25. To display the images on display pixels 22, display driver integrated circuit 16 may supply clock signals and other control signals to display driver circuitry such as row driver circuitry 18 and column driver circuitry 20. Row driver circuitry 18 and/or column

driver circuitry **20** may be formed from one or more integrated circuits and/or one or more thin-film transistor circuits on substrate **24**.

[0017] Row driver circuitry **18** may be located on the left and right edges of display **14**, on only a single edge of display **14**, or elsewhere in display **14**. During operation, row driver circuitry **18** may provide row control signals on horizontal lines **28** (sometimes referred to as row lines or “scan” lines). Row driver circuitry **18** may therefore sometimes be referred to as scan line driver circuitry. Row driver circuitry **18** may also be used to provide other row control signals, if desired.

[0018] Column driver circuitry **20** may be used to provide data signals D from display driver integrated circuit **16** onto a plurality of corresponding vertical lines **26**. Column driver circuitry **20** may sometimes be referred to as data line driver circuitry or source driver circuitry. Vertical lines **26** are sometimes referred to as data lines. During compensation operations, column driver circuitry **20** may use paths such as vertical lines **26** to supply a reference voltage. During programming operations, display data is loaded into display pixels **22** using lines **26**.

[0019] Each data line **26** is associated with a respective column of display pixels **22**. Sets of horizontal signal lines **28** run horizontally through display **14**. Power supply paths and other lines may also supply signals to pixels **22**. Each set of horizontal signal lines **28** is associated with a respective row of display pixels **22**. The number of horizontal signal lines in each row may be determined by the number of transistors in the display pixels **22** that are being controlled independently by the horizontal signal lines. Display pixels of different configurations may be operated by different numbers of control lines, data lines, power supply lines, etc.

[0020] Row driver circuitry **18** may assert control signals on the row lines **28** in display **14**. For example, driver circuitry **18** may receive clock signals and other control signals from display driver integrated circuit **16** and may, in response to the received signals, assert control signals in each row of display pixels **22**. Rows of display pixels **22** may be processed in sequence, with processing for each frame of image data starting at the top of the array of display pixels and ending at the bottom of the array (as an example). While the scan lines in a row are being asserted, the control signals and data signals that are provided to column driver circuitry **20** by circuitry **16** direct circuitry **20** to demultiplex and drive associated data signals D onto data lines **26** so that the display pixels in the row will be programmed with the display data appearing on the data lines D. The display pixels can then display the loaded display data.

[0021] Column driver circuitry **20** may output data line signals that contain grayscale information for multiple color channels, such as red, green, and blue channels. Demultiplexing circuitry **54** may demultiplex this data line signal into respective R, G, and B data line signals on respective data lines **48**. As shown in the example of FIG. 2, a display demultiplexer control circuit such as display demultiplexer control circuit **58** in column circuitry **20** may be used to supply data line demultiplexer control signals R, G, and B (corresponding to red, green, and blue channels in this example) to the gate terminals of demultiplexing transistors **60**. Data line drivers **62** may produce data line output signals SO1, SO2, . . . (sometimes referred to as source output signals) on data line paths **64**. The source output signals contain analog pixel data for image pixels of all three colors (i.e., red, blue, and green). The control signals that are applied to the gates of demultiplexing

transistors **60** turn transistors **60** on and off in a pattern that routes red channel information from the source output signals to red data lines RDL, that routes green channel information from the source output signals to green data lines GDL, and that routes blue channel information from the source output signals to blue data lines BDL.

[0022] Optional loading circuits **66** may be implemented using one or more discrete components (e.g., capacitors, inductors, and resistors) that are interposed within lines **54** or may be implemented in a distributed fashion using some or all of the structures that form lines **54**. Optional loading circuits **66** and/or circuitry in column driver circuitry **20** (e.g., circuit **58**) may be used to control the shape of the demultiplexing control signals R, G, and B. Signal shaping techniques such as these may be used to smooth display control signal pulses such as the demultiplexer control signal pulses and thereby reduce harmonic signal production and radio-frequency interference.

[0023] In an organic light-emitting diode display such as display **14**, each display pixel contains a respective organic light-emitting diode for emitting light. A drive transistor controls the amount of light output from the organic light-emitting diode. Control circuitry in the display pixel is configured to perform threshold voltage compensation operations so that the strength of the output signal from the organic light-emitting diode is proportional to the size of the data signal loaded into the display pixel while being independent of the threshold voltage of the drive transistor.

[0024] The current state of the art display pixel having threshold voltage compensation capabilities includes four thin-film transistors and an organic light-emitting diode having an associated capacitance  $C_{OLED}$ . The four transistors are controlled by two scan control signals and a single emission control signal. The resulting output signal produced by this type of display pixel may be independent of the threshold voltage of the drive transistor but may still be sensitive to the capacitance  $C_{OLED}$  of the light-emitting diode, which can cause the brightness of the display to vary over time. Other issues associated with such type of display pixels include reduced maximum brightness of the display, high power consumption, and lateral leakage between neighboring pixels. It may therefore be desirable to provide improved display pixels that address these issues.

[0025] A schematic diagram of an illustrative organic light-emitting diode display pixel **22** in display **14** in accordance with an embodiment of the present invention is shown in FIG. 3. Display pixel **22** of FIG. 3 has a storage capacitor C1 and transistors such as n-type (i.e., re-channel) transistors T1, T2, T3, T4, T5, and T6. The transistors of pixel **22** may be thin-film transistors formed from a semiconductor such as polysilicon, indium gallium zinc oxide (IGZO), etc. If desired, any one or more of transistors T1-T6 may be p-type (i.e., p-channel) thin-film transistors.

[0026] As shown in FIG. 3, display pixel **22** may include light-emitting diode **304**. A positive power supply voltage ELVDD may be supplied to positive power supply terminal **300** and a ground power supply voltage ELVSS (e.g., 0 volts or other suitable voltage) may be supplied to ground power supply terminal **302**. The state of drive transistor T2 controls the amount of current flowing from terminal **300** to terminal **302** through diode **304** and therefore the amount of emitted light **306** from display pixel **22**. Diode **304** may have an associated parasitic capacitance  $C_{OLED}$  (not shown).

[0027] Terminal 308 is used to supply an initialization voltage  $V_{ini}$  (e.g., a negative voltage such as  $-1\text{ V}$  or  $-2\text{ V}$  or other suitable voltage) to assist in turning off diode 304 when diode 304 is not in use. Control signals from display driver circuitry such as row driver circuitry 18 of FIG. 1 are supplied to control terminals such as terminals 312-1, 312-2, 314-1, and 314-2. Terminals 312-1 and 312-2 may serve respectively as first and second scan control terminals, whereas terminals 314-1 and 314-2 may serve respectively as first and second emission control terminals. Scan control signals SCAN1 and SCAN2 may be applied to scan terminals 312-1 and 312-2, respectively. Emission control signals EM1 and EM2 may be supplied to terminals 314-1 and 314-2, respectively. A data input terminal such as data signal terminal 310 is coupled to a respective data line 26 of FIG. 1 for receiving image data for display pixel 22.

[0028] In the example of FIG. 3, transistors T4, T2, T5, and diode 304 may be coupled in series between power supply terminals 300 and 302. In particular, transistor T4 may have a drain terminal that is coupled to positive power supply terminal 300, a gate terminal that receives first emission control signal EM1, and a source terminal. The terms “source” and “drain” terminals of a transistor can sometimes be used interchangeably and may therefore be referred to herein as “source-drain” terminals. Drive transistor T2 may have a first source-drain terminal SD1 that is coupled to the source terminal of transistor T4, a gate terminal, and a second source-drain terminal SD2. Transistor T5 may have a drain terminal that is coupled to the second source-drain terminal of transistor T2, a gate terminal that receives second emission control signal EM2, and a source terminal that is coupled to ground power supply terminal 302 via diode 304.

[0029] Transistor T3, capacitor C1, and transistor T6 may be coupled in series between the first source-drain terminal of drive transistor T2 and power supply terminal 308. Transistor T3 may have a first source-drain terminal that is coupled to the first source-drain terminal of transistor T2, a gate terminal that receives the second scan control signal SCAN2, and a second source-drain terminal that is coupled to the gate of transistor T2. Storage capacitor C1 may have a first terminal that is coupled to the gate of transistor T2 and a second terminal that is coupled to the source terminal of transistor T5. Transistor T6 may have a drain terminal that is coupled to the source terminal of transistor T5 (and to the p-type terminal of diode 304), a gate terminal that receives the second scan control signal SCAN2, and a source terminal that receives voltage  $V_{ini}$  via terminal 308. Transistor T1 may have a drain terminal that is coupled to the second source-drain terminal of drive transistor T2, a gate terminal that receives first scan control signal SCAN1, and a source terminal that receives data line signal DL via terminal 310. Connected in this way, signal EM1 may be asserted to enable transistor T4; signal EM2 may be asserted to activate transistor T5; signal SCAN1 may be asserted to turn on transistor T1; and signal SCAN2 may be asserted to switch into use transistors T3 and T6.

[0030] Each display pixel such as display pixel 22 of FIG. 3 may be operated in at least three repeating phases—a reset/initialization phase, a data loading and threshold voltage compensation phase, and an emission phase. During reset, threshold voltage compensation, and data loading operations, the control circuitry of display pixel 22 is used to establish a control voltage on the gate of drive transistor T2 that is independent of the threshold voltage  $V_{th}$  of drive transistor T2, that is independent of the capacitance  $C_{OLED}$  of diode 304,

and that is proportional to the magnitude of a data signal D that has been loaded into the display pixel from an associated data line 26 and terminal 310. During the subsequent emission phase, drive transistor T2 drives a corresponding current through light-emitting diode 304 so that an appropriate amount of light 306 is emitted by display pixel 22. An entire row of display pixels may be compensated and loaded with data at the same time and this process repeated for each row in the display so that all rows are compensated and loaded in this way for each frame of data or other suitable control schemes can be used for the display pixels of display 14.

[0031] FIG. 4 is a timing diagram showing the states of signals that may be applied to each display pixel 22 of FIG. 3 during the three phases of operation per image frame: 1) reset (sometimes referred to as “initialization”), 2) data input and threshold voltage compensation, and 3) emission.

[0032] During reset (e.g., from time  $t_1$  to  $t_2$ ), control signal SCAN2 is driven high to turn on transistors T3 and T6, control signal EM2 is driven low to turn off transistor T5, control signal SCAN1 remains low to keep transistor T1 in the off state, and control signal EM1 remains high to keep transistor T4 in the on state. During this time, the demultiplexing control signals R, G, and B may all be asserted to pass a maximum reference voltage level onto the corresponding data lines RDL, GDL, and BDL (see, FIG. 2).

[0033] Under these conditions, transistor T4 will pull the first source-drain terminal of drive transistor T2 up to power supply voltage ELVDD. Transistor T3 will also pull the gate terminal of transistor T2 up to ELVDD. This in turn enables transistor T2 to pull its second source-drain terminal up to at least  $(ELVDD - V_{th2})$ , where  $V_{th2}$  represents the threshold voltage of drive transistor T2. Transistor T5 is off, so organic light-emitting diode 304 is isolated from drive transistor T2 and does not emit light 306. To ensure that organic light-emitting diode 304 is turned off and does not emit light, initialization voltage  $V_{ini}$  (sometimes referred to as a “suspension” voltage) is applied to the p-type terminal (or anode) of diode 304 to reverse bias diode 304. This reverse bias may be applied to diode 304 during the reset phase and the data loading and compensation phase.

[0034] After reset operations are complete, the data input and threshold voltage compensation operations are performed. During this time (e.g., from time  $t_2$  to  $t_3$ ), control signal SCAN1 may be driven high to turn on transistor T1, control signal EM1 may be driven low to turn off transistor T4 (while signal SCAN2 remains high and while signal EM2 remains low). At time  $t_2$ , the demultiplexing control signals may be sequentially asserted to load red data signals, green data signals, and blue data signals into respective display pixels 22 via transistor T1. Under these conditions, transistor T1 will drive the second source-drain terminal of transistor T2 to data signal level  $V_{data}$  while the first source-drain terminal and the gate terminal of transistor T2 are both pulled down to  $(V_{data} + V_{th2})$ .

[0035] After data input and threshold voltage compensation operations, emission operations are performed. During emission operations, control signal SCAN2 is driven low to turn off transistors T3 and T6, control signal EM2 is driven high to turn on transistor T5, control signal SCAN1 is driven low to turn off transistor T1, and control signal EM1 is driven back high to activate transistor T4. With transistor T6 turned off, the p-type terminal of diode 304 is isolated from voltage  $V_{ini}$ . With transistor T1 turned off, data terminal 310 is isolated from the drive transistor. Because transistors T4, T2, and

T5 are all turned on, a current  $I_{OLED}$  may flow from power supply terminal 300 via these series connected transistors and diode 304 to power supply terminal 304, thereby causing diode 304 to produce a corresponding amount of light 306. This may result in a voltage drop  $V_{OLED}$  across diode 306.

[0036] Under these conditions, the first source-drain terminal of drive transistor T2 may be driven to ELVDD, and the source terminal of transistor T5 may be held at  $(V_{OLED} + ELVSS)$ , which will also pull the second source-drain terminal of transistor T2 down to  $(V_{OLED} + ELVSS)$ . At time 3, the voltage at the p-type terminal of diode 304 may therefore change from Vini to  $(V_{OLED} + ELVSS)$ , which results in a net voltage change of  $(V_{OLED} + ELVSS - Vini)$ . Since the voltage across capacitor C1 cannot change instantaneously, this voltage change at the second terminal of capacitor C1 will cause the first terminal of capacitor C1 to change from  $(Vdata + Vth2)$  to  $[(Vdata + Vth2) + (V_{OLED} + ELVSS - Vini)]$ . Since the first terminal of capacitor C1 is shorted to the gate terminal of drive transistor T2, the gate terminal of transistor T2 will therefore exhibit a voltage level of  $[(Vdata + Vth2) + (V_{OLED} + ELVSS - Vini)]$  during emission.

[0037] With these voltages established at the various terminals of drive transistor T2, the drive current  $I_{OLED}$  that flows through transistor T2 is given by  $I_{OLED} = k * (V_{GS} - Vth2)^2$ . Substituting  $V_{GS}$  with the difference between the voltage at the gate terminal of transistor T2 (which is equal to  $[(Vdata + Vth2) + (V_{OLED} + ELVSS - Vini)]$ , as described above) and the voltage at the second source-drain terminal of transistor T2 (which is equal to  $[ELVSS - V_{OLED}]$ , as described above), we obtain  $I_{OLED} = k * [Vdata - Vini]^2$ . As this equation demonstrates, the magnitude of drive current  $I_{OLED}$  is proportional to the magnitude of data signal Vdata and is independent of threshold voltage Vth2 and  $V_{OLED}$  (i.e., compensation operations have been successfully performed, so that light emission is neither affected by Vth variations nor by variations associated with diode 304). In other words, operating display pixel 22 in the way shown in FIG. 4 can help provide reduced sensitivity to both threshold voltage variations and reduced sensitivity to any parasitic capacitance  $C_{OLED}$  associated with diode 304.

[0038] Simulations have been performed to evaluate the operation of the circuit of FIG. 3. These simulations indicate that light output 306 of light-emitting diodes such as diode 304 of FIG. 3 will not be significantly affected by drive transistor threshold voltage hysteresis and response time for display 14 will therefore be satisfactory. The output magnitude of a white pixel (as one example) will be substantially the same regardless of whether the state of the pixel was black in the prior frame or was white in the prior frame. Moreover, the brightness of display pixel 22 can be dynamically controlled by adjusting Vini without increasing the required data range. The use of transistor T5 to isolate the anode of diode 304 and the use of transistor T6 to keep the anode of diode 304 initialized at suspension voltage Vini for the majority of the pixel operation helps to improve pixel response time and reduce lateral leakage.

[0039] Another suitable arrangement of a display pixel 22 that can be used in display 14 of FIG. 1 is shown in FIG. 5. The pixel implementation of FIG. 5 requires only one scan control line and one emission control line per row. The emission control line can, however, be shared between adjacent rows. Similar to the embodiment of FIG. 3, display pixel 22 of FIG. 5 has a storage capacitor C1 and transistors such as n-channel transistors T1, T2, T3, T4, T5, and T6. The transistors of

pixel 22 may be thin-film transistors formed from a semiconductor such as polysilicon, indium gallium zinc oxide (IGZO), etc. If desired, any one or more of transistors T1-T6 may be p-channel thin-film transistors.

[0040] As shown in FIG. 5, display pixel 22 may include light-emitting diode 504. A positive power supply voltage ELVDD may be supplied to positive power supply terminal 500 and a ground power supply voltage ELVSS (e.g., 0 volts or other suitable voltage) may be supplied to ground power supply terminal 502. The state of drive transistor T2 controls the amount of current flowing from terminal 500 to terminal 502 through diode 504 and therefore the amount of emitted light 506 from display pixel 22. Diode 504 may have an associated parasitic capacitance  $C_{OLED}$  (not shown).

[0041] Terminal 508 is used to supply an initialization voltage Vini (e.g., a negative voltage such as -1 V or -2 V or other suitable voltage) to assist in turning off diode 504 when diode 504 is not in use. Control signals from display driver circuitry such as row driver circuitry 18 of FIG. 1 are supplied to control terminals such as terminals 512, 514[n], and 514[n-1]. Terminals 512 may serve as a scan control terminal that receives SCAN. Terminal 514[n] may serve as an emission control terminal that is associated with a particular row n, whereas terminal 514[n-1] may serve as an emission control terminal that is associated with an immediately preceding row (n-1). Emission control signals EM[n] and EM[n-1] may be supplied to terminals 514[n] and 514[n-1], respectively. A data input terminal such as data signal terminal 510 is coupled to a respective data line 26 of FIG. 1 for receiving image data for display pixel 22.

[0042] In the example of FIG. 5, transistors T4, T2, T5, and diode 504 may be coupled in series between power supply terminals 500 and 502. In particular, transistor T4 may have a drain terminal that is coupled to positive power supply terminal 500, a gate terminal that receives emission control signal EM[n], and a source terminal. Drive transistor T2 may have a first source-drain terminal SD1 that is coupled to the source terminal of transistor T4, a gate terminal, and a second source-drain terminal SD2. Transistor T5 may have a drain terminal that is coupled to the second source-drain terminal of transistor T2, a gate terminal that receives emission control signal EM[n-1], and a source terminal that is coupled to ground power supply terminal 502 via diode 504.

[0043] Transistor T3 may have a first source-drain terminal that is coupled to the first source-drain terminal of transistor T2, a gate terminal that receives scan control signal SCAN, and a second source-drain terminal that is coupled to the gate of transistor T2. Storage capacitor C1 may have a first terminal that is coupled to the gate of transistor T2 and a second terminal that is coupled to the source terminal of transistor T5. Transistor T6 may have a drain terminal that is coupled to the source terminal of transistor T5 (and to the anode of diode 504), a gate terminal that receives the scan control signal SCAN, and a source terminal that receives voltage Vini via terminal 508. Transistor T1 may have a drain terminal that is coupled to the second source-drain terminal of drive transistor T2, a gate terminal that receives scan control signal SCAN, and a source terminal that receives data line signal DL via terminal 510. Connected in this way, signal EM[n] may be asserted to enable transistor T4; signal EM[n-1] may be asserted to activate transistor T5; and signal SCAN may be asserted to turn on transistor T1, T3, and T6 simultaneously.

[0044] Each display pixel such as display pixel 22 of FIG. 5 may be operated in at least four repeating phases—a reset/

initialization phase, a data loading and threshold voltage compensation phase, a holding phase, and an emission phase. FIG. 6 is a timing diagram showing the states of signals that may be applied to each display pixel 22 of FIG. 5 during the four phases of operation per image frame. As shown in FIG. 6, signal EM[n] may simply be a delayed version of EM[n-1] since EM[n-1] is effectively being borrowed from the immediately preceding row.

[0045] During reset (e.g., from time t1 to t2), control signal SCAN is driven high to turn on transistors T1, T3 and T6, control signal EM[n-1] remains low to keep transistor T5 in the off state, and control signal EM[n] remains high to keep transistor T4 in the on state. During this time, the demultiplexing control signals R, G, and B may all be asserted to pass a maximum reference voltage level onto the corresponding data lines RDL, GDL, and BDL (see, FIG. 2).

[0046] Transistor T5 is off, so organic light-emitting diode 504 is isolated from drive transistor T2 and does not emit light 506. To ensure that organic light-emitting diode 504 is turned off and does not emit light, initialization voltage Vini is applied to the anode of diode 504 to reverse bias diode 504. This reverse bias may be applied to diode 504 during the reset phase and the data loading and compensation phase.

[0047] After reset operations are complete, the data input and threshold voltage compensation operations are performed. During this time (e.g., from time t2 to t3), control signal SCAN may remain high to keep transistors T1, T3, and T6 in the on state, control signal EM[n-1] may remain low to keep transistor T5 in the off state, whereas control signal EM[n] may be driven low to deactivate transistor T4. At time t2, the demultiplexing control signals may be sequentially asserted to load red data signals, green data signals, and blue data signals into respective display pixels 22 via transistor T1. Under these conditions, transistor T1 will drive the second source-drain terminal of transistor T2 to data signal level Vdata while the first source-drain terminal and the gate terminal of transistor T2 are both pulled down to (Vdata+Vth2).

[0048] After data input and threshold voltage compensation operations, data may be held during a holding phase from time t3 to t5. In particular, control signal SCAN may be driven low at time t3 to turn off transistors T1, T3, and T6, and control signal EM[n-1] may be driven high at time t4 to turn on transistor T5.

[0049] At the end of the holding phase, emission operations are performed. During emission operations, control signal EM[n] may be driven high (i.e., at time t5) to turn on transistor T4. With transistor T6 turned off, the anode of diode 504 is isolated from voltage Vini. With transistor T1 turned off, data terminal 510 is isolated from the drive transistor T2. Because transistors T4, T2, and T5 are all turned on, a current  $I_{OLED}$  may flow from power supply terminal 500 via these series connected transistors and diode 504 to power supply terminal 504, thereby causing diode 504 to produce a corresponding amount of light 506. Similar to the pixel arrangement of FIG. 3, the magnitude of drive current  $I_{OLED}$  may be proportional to the magnitude of data signal Vdata but is independent of threshold voltage Vth2 and  $V_{OLED}$ . In other words, operating display pixel 22 in the way shown in FIG. 5 can help provide reduced sensitivity to both threshold voltage variations and reduced sensitivity to any parasitic capacitance  $C_{OLED}$  associated with diode 504.

[0050] Simulations have been performed to evaluate the operation of the circuit of FIG. 6. These simulations indicate that light output 506 of light-emitting diodes such as diode

504 of FIG. 5 will not be significantly affected by drive transistor threshold voltage hysteresis and response time for display 14 will therefore be satisfactory. The output magnitude of a white pixel (as one example) will be substantially the same regardless of whether the state of the pixel was black in the prior frame or was white in the prior frame. Moreover, the brightness of display pixel 22 can be dynamically controlled by adjusting Vini without increasing the required data range. The use of transistor T5 to isolate the anode of diode 504 and the use of transistor T6 to keep the anode of diode 504 initialized at suspension voltage Vini for the majority of the pixel operation helps to improve pixel response time and reduce lateral leakage.

[0051] The foregoing is merely illustrative and various modifications can be made by those skilled in the art without departing from the scope and spirit of the described embodiments. The foregoing embodiments may be implemented individually or in any combination.

What is claimed is:

1. A display pixel, comprising:

an organic light-emitting diode having an associated capacitance;

a plurality of transistors one of which is a drive transistor that supplies a current to the organic light-emitting diode; and

a capacitor coupled to the drive transistor and the organic light-emitting diode, wherein the plurality of transistors receive control signals during operation of the display pixel that compensate for variations in the capacitance of the organic light-emitting diode.

2. The display pixel defined in claim 1, wherein the plurality of transistors comprises n-type transistors.

3. The display pixel defined in claim 1, wherein the capacitor comprises the only capacitor in the display pixel.

4. The display pixel defined in claim 1, wherein the plurality of transistors comprises first, second, third, fourth, fifth, and sixth transistors, and wherein the second transistor is the drive transistor.

5. The display pixel defined in claim 4, further comprising:

a first power supply terminal; and

a second power supply terminal, wherein the second, fourth, and fifth transistors and the organic light-emitting diode are coupled in series between the first and second power supply terminals.

6. The display pixel defined in claim 5, wherein the drive transistor has a gate terminal and first and second source-drain terminals, the display pixel further comprising:

a data line, wherein the first transistor is coupled between the data line and the second source-drain terminal of the drive transistor.

7. The display pixel defined in claim 6, further comprising:

a third power supply line on which an initialization voltage is provided, wherein the third transistor, the sixth transistor, and the capacitor are coupled in series between the first source-drain terminal of the drive transistor and the third power supply line.

8. The display pixel defined in claim 7, wherein each of the first, second, third, fourth, fifth, and sixth transistors has a gate terminal, the display pixel further comprising:

a first scan line that is coupled to the gate terminal of the first transistor;

a second scan line that is different than the first scan line and that is coupled to the gate terminals of the third and sixth transistors;

- a first emission control line that is coupled to the gate terminal of the fourth transistor; and  
 a second emission control line that is different than the first emission control line and that is coupled to the gate terminal of the fifth transistor.
9. The display pixel defined in claim 7, wherein each of the first, second, third, fourth, fifth, and sixth transistors has a gate terminal, the display pixel further comprising:  
 a scan line that is coupled to the gate terminal of the first, third, and sixth transistors;  
 a first emission control line on which a first emission control signal is provided, wherein the first emission control line is coupled to the gate terminal of the fourth transistor; and  
 a second emission control line on which a second emission control signal is provided, wherein the second emission control line is coupled to the gate terminal of the fifth transistor, and wherein the first emission control signal is a delayed version of the second emission control signal.
10. The display pixel defined in claim 1, wherein the drive transistor has a threshold voltage, and wherein the plurality of transistors receive the control signals during operation of the display pixel that compensate for variations in the threshold voltage of the drive transistor.
11. Display circuitry, comprising:  
 an array of display pixels arranged in rows and columns, wherein each display pixel in the array includes an organic light-emitting diode and first, second, third, fourth, fifth, and sixth transistors;  
 a first emission control line that supplies a first emission control signal to display pixels arranged along a first row of display pixels in the array; and  
 a second emission control line that supplies a second emission control signal from a second row of display pixels in the array to the first row of display pixels in the array.
12. The display circuitry defined in claim 11, wherein the second transistor in each display pixel is a drive transistor that supplies a current to the organic light-emitting diode in that display pixel, wherein the organic light-emitting diode has an associated parasitic capacitance, wherein each display pixel in the array further includes only one capacitor that is coupled to the drive transistor and the organic light-emitting diode in that display pixel, and wherein the first, second, third, fourth, fifth, and sixth transistors receive control signals during operation of the display circuitry that compensate for variations in the capacitance of the organic light-emitting diode.
13. The display circuitry defined in claim 12, wherein the drive transistor in each display pixel has a threshold voltage, and wherein the first, second, third, fourth, fifth, and sixth transistors receive the control signals during operation of the display circuitry that compensate for variations in the threshold voltage of the drive transistor.
14. The display circuitry defined in claim 11, wherein the first, second, third, fourth, fifth, and sixth transistors comprises n-channel thin-film transistors.
15. The display circuitry defined in claim 11, wherein the first emission control signal on the first emission control line is a delayed version of the second emission control signal on the second emission control line.
16. The display circuitry defined in claim 11, further comprising:  
 only one scan control line that supplies a scan control signal to the display pixels arranged along the first row of display pixels in the array.
17. A method for operating a display pixel having an organic light-emitting diode, six transistors, and a capacitor, comprising:  
 during a reset phase, driving an anode of the organic light-emitting diode to an initialization voltage level, wherein the organic light-emitting diode has an associated capacitance;  
 during a data input phase, driving the anode of the organic light-emitting diode to the initialization voltage level and loading data into an internal node of the display pixel; and  
 during an emission phase, passing a drive current through the organic light-emitting diode, wherein the drive current is independent of the capacitance of the organic light-emitting diode.
18. The method defined in claim 17, wherein one of the six transistors is a drive transistor having a threshold voltage, the method further comprising:  
 performing threshold voltage compensation operations during the data input phase such that the drive current is also independent of the threshold voltage of the drive transistor.
19. The method defined in claim 17, further comprising:  
 using at least two different scan control signals to control the display pixel; and  
 using at least two different emission control signals to control the display pixel.
20. The method defined in claim 17, wherein the display pixel comprises one display pixel in an array of display pixels arranged in rows and columns, the method further comprising:  
 using only one scan control signal to control the display pixel; and  
 using a first emission control line associated with a first row of display pixels in the array and a second emission control line associated with a second row of display pixels in the array that is adjacent to the first row to control the display pixel.

\* \* \* \* \*

|                |  |         |            |
|----------------|--|---------|------------|
| 专利名称(译)        | 有机发光二极管显示器，具有降低的电容灵敏度  |         |            |
| 公开(公告)号        | <a href="#">US20160063921A1</a>  | 公开(公告)日 | 2016-03-03 |
| 申请号            | US14/469513  | 申请日     | 2014-08-26 |
| [标]申请(专利权)人(译) | 苹果公司   |         |            |
| 申请(专利权)人(译)    | 苹果公司.  |         |            |
| 当前申请(专利权)人(译)  | 苹果公司.  |         |            |
| [标]发明人         | TSAI TSUNG TING<br>GUPTA VASUDHA<br>LIN CHIN WEI<br>CHANG SHIH CHANG<br>PARK YOUNG BAE   |         |            |
| 发明人            | TSAI, TSUNG-TING<br>GUPTA, VASUDHA<br>LIN, CHIN-WEI<br>CHANG, SHIH-CHANG<br>PARK, YOUNG, BAE   |         |            |
| IPC分类号         | G09G3/3258 G09G3/32  |         |            |
| CPC分类号         | G09G3/3258 G09G2310/061 G09G2320/0252 G09G3/3233 G09G2300/0819 G09G2300/0842<br>G09G2300/0861 G09G2310/0262 G09G2310/0297 G09G2320/045 |         |            |
| 外部链接           | <a href="#">Espacenet</a> <a href="#">USPTO</a>  |         |            |

摘要(译)

显示器可以具有有机发光二极管显示像素的阵列。每个显示像素可以具有在驱动晶体管的控制下发光的发光二极管。每个显示像素还可以具有用于补偿和编程操作的控制晶体管。每个显示像素可以具有六个薄膜晶体管和一个电容器。六个晶体管中的一个可以用作驱动晶体管，并且可以使用剩余的五个晶体管和电容器来补偿。电容器可以具有耦合到驱动晶体管的栅极的第一端子和耦合到发光二极管的第二端子。在一个实施例中，两个扫描控制信号和两个发射控制信号可以用于每行显示像素。在另一个实施例中，可以为每行显示像素形成单个扫描控制信号和单个发射控制信号。

